

PRODUCT- TJM SINGLE COMPRESSOR MOUNTING BRACKET

VEHICLE- TOYOTA HILUX 2015+

PART NUMBER- JBA-CB255, JBA-CB255KIT1

ESTIMATED FIT TIME

- | | |
|--|-------------|
| - PREPERATION AND MOUNTING OF COMPRESSOR AND BRACKET | 90-120 MINS |
| - ELECTRICAL WIRING AND PLUMBING OF AIR OUTLETS | 60-90 MINS |

IMPORTANT NOTES

- READ INSTRUCTIONS CAREFULLY PRIOR TO FITMENT
- ENSURE 567 THREAD SEALANT IS APPLIED TO ALL AIR THREADS INSTALLED
- REFER TO TJM COMPRESSOR INSTALLATION INSTRUCTIONS FOR WIRING SPECIFICATIONS
- NITTO FITTING USED WITH KITS ARE SUPPLIED SEPERATLEY (NOT BY JBA) AVAILABLE THROUGH TJM STORES (P/N 013COMPPF01)

KIT CONTENTS

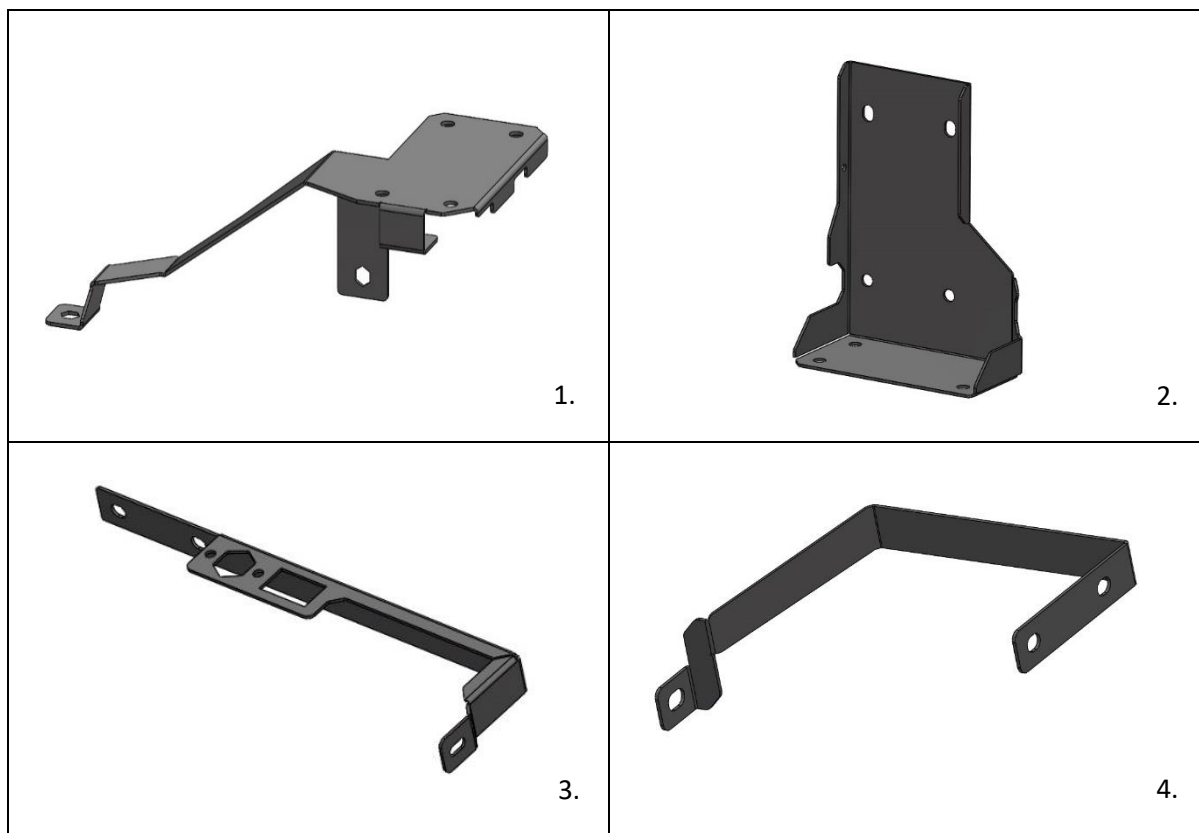

ITEM	DESCRIPTION	PART NO.	QTY
1	JBA HILUX 2015+ BASE BRACKET	10-CB255A	1
2	JBA HILUX 2015+ COMPRESSOR MOUNT BRACKET	10-CB255B	1
3	JBA HILUX 2015+ OUTLET SUPPORT BRACKET	10-CB255C	1
4	JBA HILUX 2015+ REAR SUPPORT BRACKET	10-CB255D	1
5	M6 X 12MM SEMS ASSMEMBLY Z/Y	JNS-22	1
6	M6 X 20MM SEMS ASSMEMBLY Z/Y	B48 0620ZY	2
7	M8 X 20MM SEMS ASSMEMBLY Z/Y	JNS-32	1
8	M6 NUT ON WIRE	JBA-NW01	1
9	M8 X 20MM BUTTON HD SOCKET SCR GR 304 S/S	X72 08016304	8
10	5/16 X 3/4 X 18G FLAT WASHER GR 304 S/S	X79 082018G304	17
11	M8 NYLON INSERT LOCK NUT GR 304S/S	X53 8304	9
12	M4 X 12MM PAN HD PHIL M/T GR 304 S/S	X37 0412PP304	1
13	M4 HEX SERR FLANGE NUT ZY	N24 04ZY	1

OPTIONAL KIT PARTS- JBA-CB255KIT1

ON BRACKET SWITCH/AIR OUTLETS

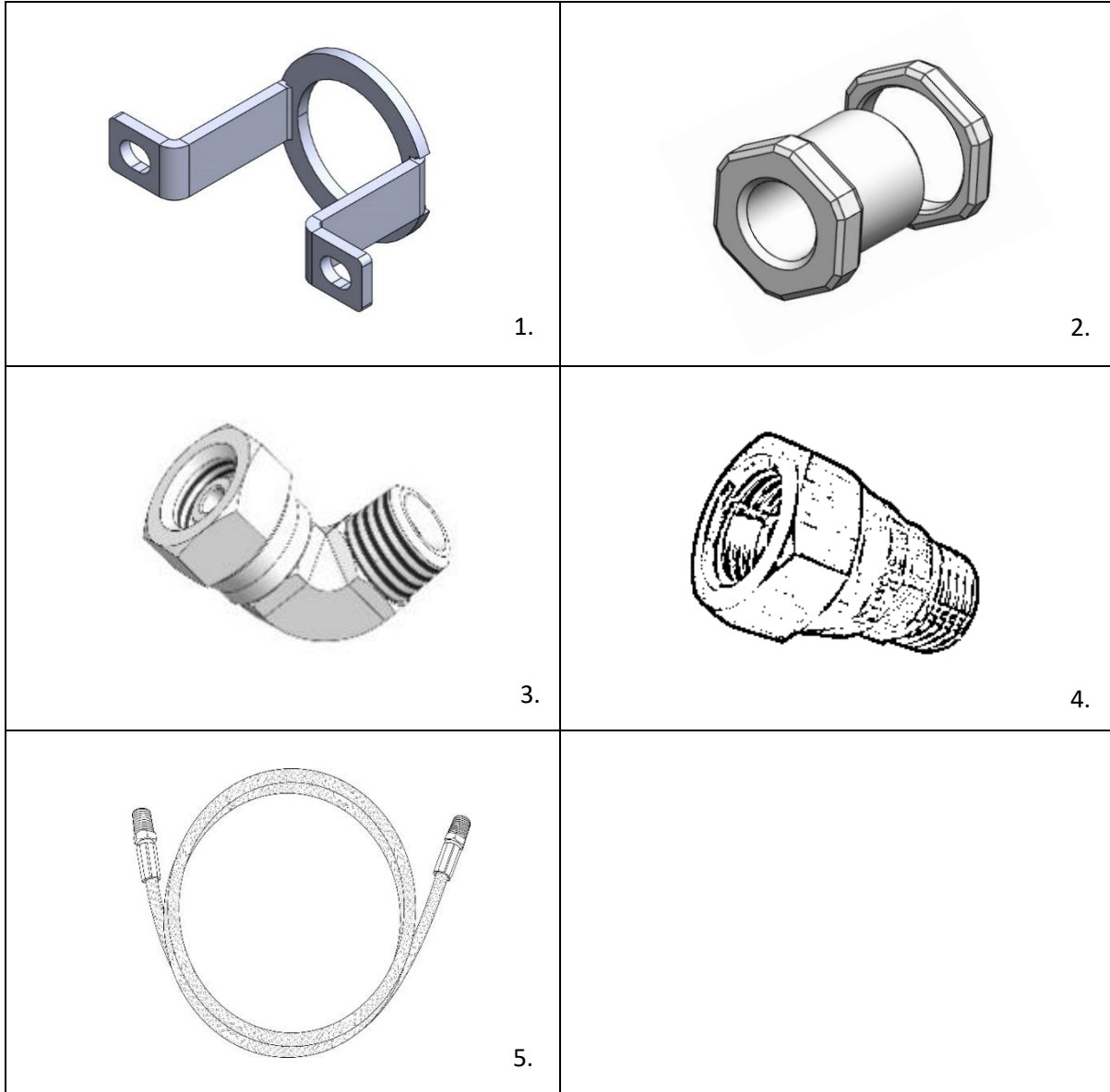

ITEM	DESCRIPTION	PART NO.	QTY
1	JBA BULK HEAD RECESSED HOUSING BRACKET	JBA-CB101B	1
2	JBA STAINLESS BULK HEAD	JBA-CB103	1
3	JBA STAINLESS ELBOW 90 DEGREE	JBA-CB106	1
4	JBA STAINLESS ELBOW 0 DEGREE	JBA-CB104	1
4	JBA STAINLESS HOSE 400MM	JBA-CB111	1
5	M4 X 16 CSK GR 304 S/S	X37 0416CP304	2
6	M4 NYLOC NUT GR 304 S/S	X53 4304	2
7	M4 X 10 WASHER GR 304 S/S	X80 4090.8304	2

1. PREPARING THE COMPRESSOR AND BRACKET



STEP 1.1 ATTACH THE BASE BRACKET AND MOUNTING BRACKET USING M8 X 20 DOME HEAD, WASHERS AND NYLOC NUT.

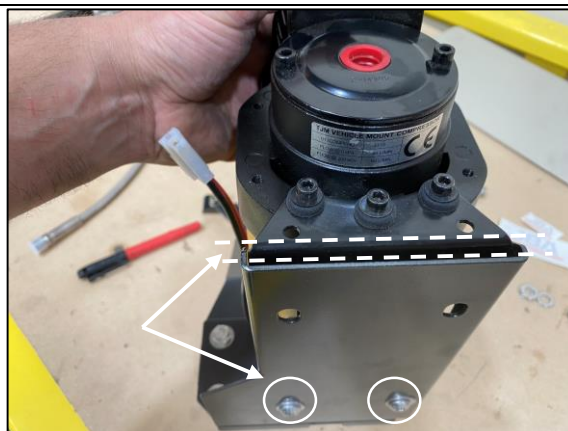

STEP 1.2 BOLT THE TJM COMPRESSOR TO THE MOUNTING BRACKET IN THE ORIENTATION SHOWN. PUSH THE COMPRESSOR UP SO IT IS JUST ABOVE THE JBA BRACKET AS SHOWN AND FASTEN BOTTOM 2 X BOLTS ONLY.



STEP 1.3 ATTACH THE TJM RELAY USING M4 X 12 PAN HEAD AND FLANGE NUT AS SHOWN.



STEP 1.4 BOLT ON THE OUTLET SUPPORT BRACKET (10-CB255C) FINGER TIGHT (BOLTS NEED TO BE REMOVED LATER)



STEP 1.5 IF INSTALLING JBA-KIT1 AIR/SWITCH OPTION, INSTALL JBA-CB106 90 DEGREE ELBOW AS SHOWN (REFER TO STEPS 2 BELOW FOR FURTHER DETAILED STEPS ON AIR OUTLET).



STEP 1.6 INSTALL TJM PRESSURE SWITCH NEXT TO 90 DEGREE ELBOW.

2. OPTIONAL STEPS- JBA-CB255KIT1 AIR/SWITCH FITMENT



STEP 2.1 FIT THE TJM NITTO FITTING (NOT SUPPLIED BY JBA) TO THE JBA-CB103 BULKHEAD AND NUT. ENSURE THE FLAT FACES ALIGN AS SHOWN.



STEP 2.2 INSTALL JBA-CB101B HOUSING TO SUPPORT BRACKET USING M4 X 16 CSK HEAD SCREW, WASHERS AND NYLOC NUT AS SHOWN.

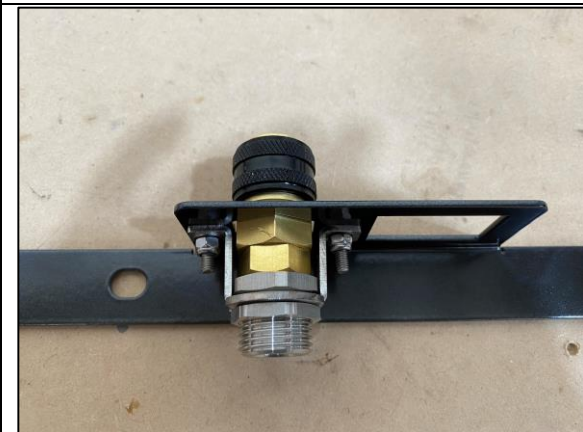

STEP 2.3 FIT BULK HEAD AND NITTO AS SHOWN. **ENSURE LOCTITE IS APPLIED TO THE NUT ON REAR.**



STEP 2.4 FIT JBA-CB104 0 DEGREE FITTING TO BULK HEAD AND CONNECT 400MM HOSE AS SHOWN.

3. INSTALLING THE BRACKET AND COMPRESSOR INTO THE VEHICLE



STEP 3.1 BEND THE AIR CONDITIONER PIPES AWAY FROM THE BODY APPROX 5MM TO ENSURE CLEARANCE FOR NEXT STEP.

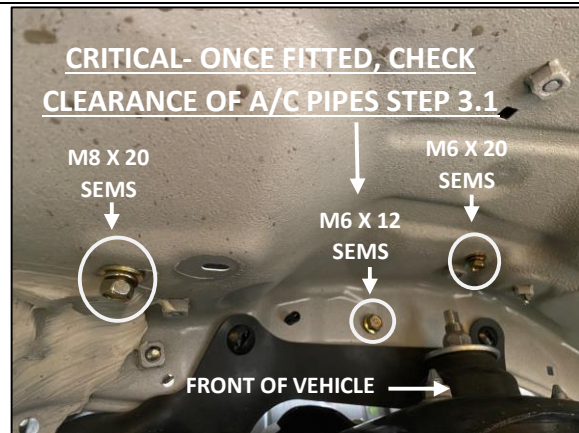

STEP 3.2 LIFT THE COMPRESSOR BRACKET INTO POSITION IN THE ENGINE BAY. START EACH SCREW FINGER TIGHT UNDER THE WHEEL ARCH AS SHOWN. **CHECK CLEARANCE IN ENGINE BAY OF A/C PIPES.**



STEP 3.3 BEND THE NUT ON WIRE AND FEED THROUGH GUARD AS SHOWN. FASTEN OUTLET SUPPORT BRACKET USING M6 X 20 SEMS FINGER TIGHT.



STEP 3.4 REMOVE THE TWO TOP M8 X 20 DOME HEAD BOLTS AND LOOSELY INSTALL REAR SUPPORT BRACKET (10-CB255D).



STEP 3.5 SLIDE THE OTHER END OF THE REAR SUPPORT BRACKET OVER THE M8 STUD ON THE BRAKE BOOSTER AND FASTEN USING M8 WASHER AND NYLOC NUT.



STEP 3.6 FULLY TIGHTEN ALL FASTENERS AND COMPLETE WIRING AS PER TJM WIRING INSTRUCTIONS. CABLE TIE ANY LOOMS/HOSES NEATLY AND CYCLE/TEST COMPRESSOR AND CONNECTIONS.