

PRODUCT- TJM 5L AIR TANK MOUNTING BRACKET

VEHICLE- 200 SERIES LANDCRUISER 2007-2021

PART NUMBER- JBA-CB301

ESTIMATED FIT TIME

- PREPERATION AND MOUNTING OF COMPRESSOR AND BRACKET 30 MINS

IMPORTANT NOTES

- READ INSTRUCTIONS CAREFULLY PRIOR TO FITMENT
- ENSURE 567 THREAD SEALANT IS APPLIED TO ALL AIR THREADS INSTALLED

KIT CONTENTS

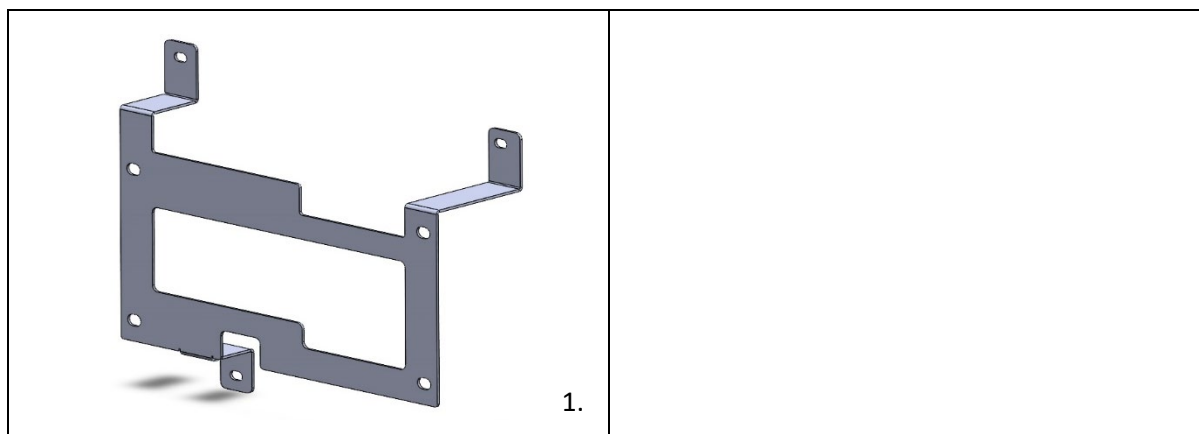

ITEM	DESCRIPTION	PART NO.	QTY
1	JBA 200 SERIES 5L TANK BRACKET	JBA-CB301A	1
2	M8 X 20MM BUTTON HD SOCKET SCR GR 304 S/S	X72 08020304	4
3	5/16 X 3/4 X 18G FLAT WASHER GR 304 S/S	X79 082018G304	4
4	M8 NYLON INSERT LOCK NUT GR 304S/S	X53 8304	4
5	M6 X 20MM SEMS ASSMEMBLY Z/Y	B48 0620ZY	3
6	M6 HEX SERR FLANGE NUT ZY	N24 06ZY	1

1. PREPARING THE TANK AND BRACKET



STEP 1.1 USING A 5MM ALLEN KEY, LOOSEN OFF THE GRUB SCREW ON EACH TANK FOOT AND SLIDE OFF THE TANK.

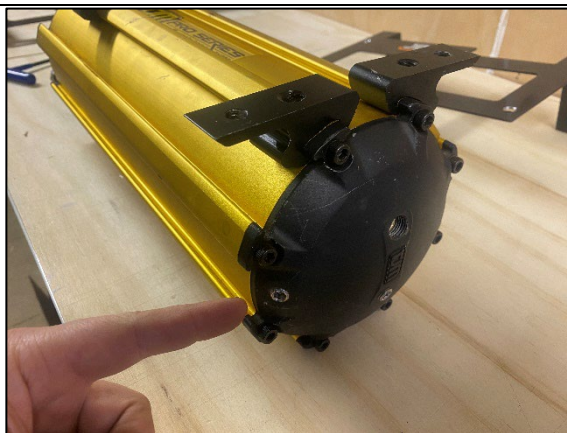

STEP 1.2 ROTATE THE TANK SO THAT THE DRAIN SCREW IS 90 DEGREES FACING YOU AS SHOWN. SLIDE THE TANK FEET BACK ON TOP FACE (ALONG TJM STICKER)

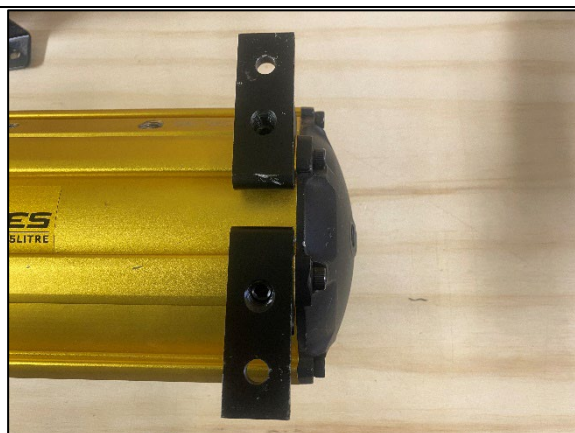

STEP 1.3 ALIGN THE RIGHT SIDE FEET LEVEL WITH THE END OF THE TANK AS SHOWN AND TIGHTEN.

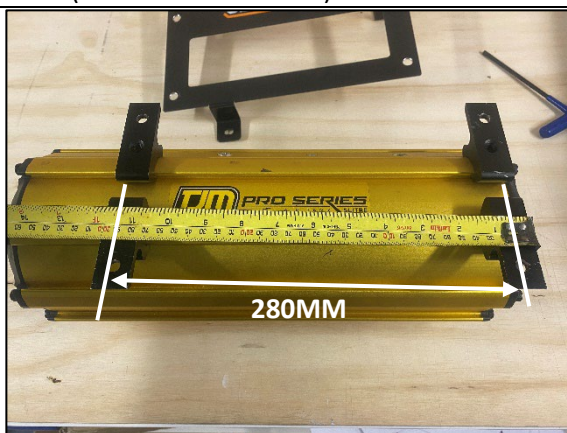

STEP 1.4 POSITION THE LEFT SIDE FEET 280MM (CENTRE TO CENTRE) FROM THE RIGHT FEET AND TIGHTEN.

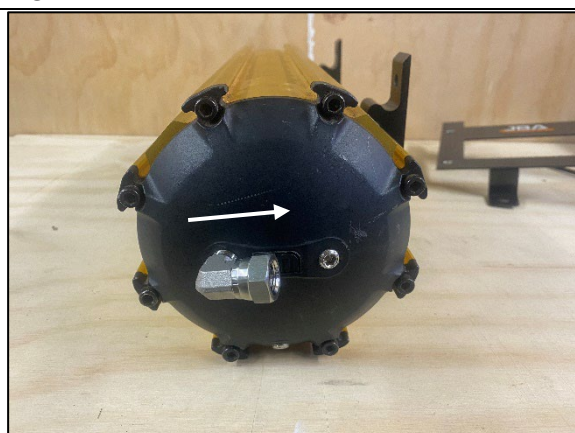

STEP 1.5 INSTALL JBA-CB106 90 DEGREE ELBOW ON THE END OF THE TANK AS SHOWN FACING TOWARDS THE TANK FEET.



STEP 1.6 INSTALL SECOND JBA-CB106 90 DEGREE ELBOW IN THE LHS 1/4" BSP OUTLET ON THE TANK AS SHOWN FACING TOWARDS THE RHS.



STEP 1.7 ATTACH JBA STAINLESS HOSES TO ELBOWS PREVIOUSLY INSTALLED IN STEPS 1.5-1.6.

- INSTALL 800MM HOSE TO ELBOW ON LHS END WHICH WILL CONNECT TO THE COMPRESSOR.
- IF INSTALLING JBA-CB201QAS QUARTER PANEL MOUNT BRACKET, INSTALL 800MM HOSE TO ELBOW ON TOP OF TANK
- IF INSTALLING JBA-CB101 DRAWER FRONT MOUNT, INSTALL 1200MM HOSE TO ELBOW ON TOP OF TANK.



STEP 1.8 ATTACH THE TANK TO THE JBA BRACKET USING M8 X 20 PAN HEAD WITH A WASHER UNDER THE HEAD AS SHOWN. FASTEN FROM UNDERNEATH USING M8 NYLOC AND WASHER.

OPTIONAL STEPS- FITTING TANK DRAIN KIT



STEP 1.9 INSTALL JBA 90 DEGREE QUICK FIT ELBOW TO 1/8" PORT AT THE BOTTOM OF THE TANK AS SHOWN.



STEP 1.10 INSTALL 8MM HOSE AND DRAIN VALVE.

2. INSTALLING IN TO THE VEHICLE



STEP 2.1 POSITION BRACKET INTO VEHICLE LINING UP THE FACTORY BODY POINTS. INSTALL TOP LEFT AND BOTTOM POSITIONS USING M6 X 20 SEMS SCREW AND TOP RIGHT POINT USING M6 X 20 SEMS WITH M6 FLANGE NUT FROM BEHIND.



STEP 2.2 CONTINUE INSTALLATION AS PER JBA-CB201 SINGLE OR JBA-CB211 TWIN COMPRESSOR INSTRUCTIONS AND RELEVANT AIR OUTLET LOCATION SPECIFICATIONS.