

PRODUCT- JBA ROK9 MOUNTING BRACKET

APPLICATIONS

- RHINO V4 SIDE MOUNT
- RHINO V5/V6 REAR MOUNT
- TRADESMAN WEDGETAIL SIDE MOUNT

PART NUMBER- JB-LB101/102

ESTIMATED FIT TIME- 30 MINS

IMPORTANT NOTES

- READ INSTRUCTIONS CAREFULLY PRIOR TO FITMENT
- IT IS RECOMMENDED TO REMOVE THE RACK FROM THE VEHICLE TO MAKE INSTALLATION EASIER

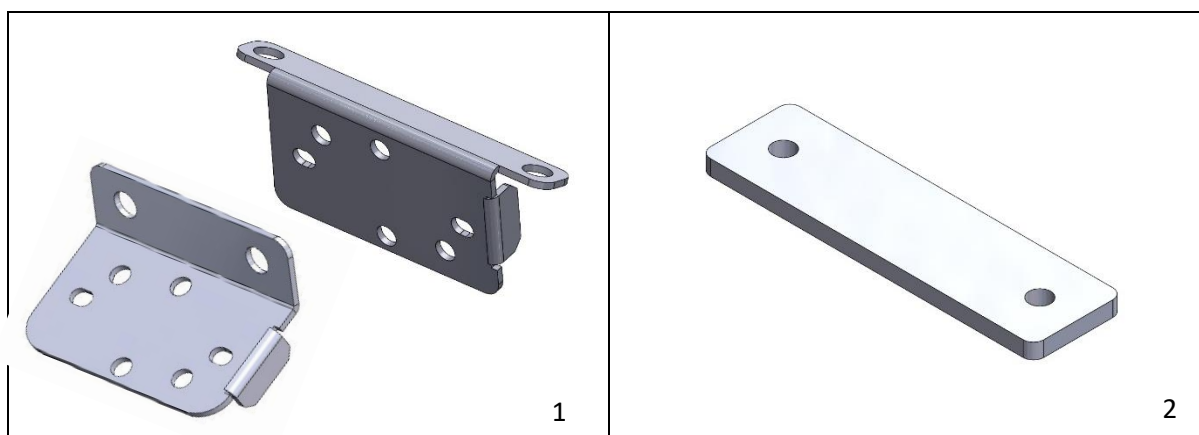

KIT CONTENTS

ITEM	DESCRIPTION	PART NO.	QTY
1	FLUSH MOUNT BACKBONE ROK9 BRACKET	10-LB101/102	1
2	ROK9 NUT PLATE	10-LB191	1
3	M5 X 10 X 0.8MM FLAT WASHER GR 304 S/S	X80 5100.8304	4
4	M5 NYLON INSERT LOCK NUT GR 304S/S	X53 5304	4
5	M5 X 16MM PAN HD PHIL M/T GR 304 S/S	X37 0516PP304	2
6	M5 X 12MM CSK HD PHIL M/T GR 304 S/S	X37 0512CP304	2
7	M8 X 16MM BUTTON HEAD SOCKET SCREW GR 8.8 316 S/S	X72 08016304	2
8	M8 X 17 X 1.2MM FLAT WASHER GR 304 S/S	X80 8171.2304	2
9	M8 NYLON INSERT LOCK NUT GR 304S/S	X53 8304	2
10	M8 SPRING WASHER GR304 S/S	X82 06304	2

1. INSTALL TO V4 RHINO SIDEMOUNT



STEP 1- SELECT MOUNTING POSITION
(NORMALLY EVEN DISTANCE FROM EACH END)
NORMALLY ONE HOLE WILL LINE UP WITH A
SLOT IN THE RACK. MARK AND DRILL THE
OTHER HOLE TO 6MM.



STEP 2- MOUNT THE BRACKET USING M5 X 12
CSK HEAD SCREWS WITH WASHER AND NYLOC
NUT FROM REAR.
MOUNT THE ROK9 TO THE JBA BRACKET USING
M5 X 16 PAN HEAD WITH WASHER AND NYLOC
NUT FROM REAR

2. INSTALL TO RHINO V5/V6 REAR MOUNT

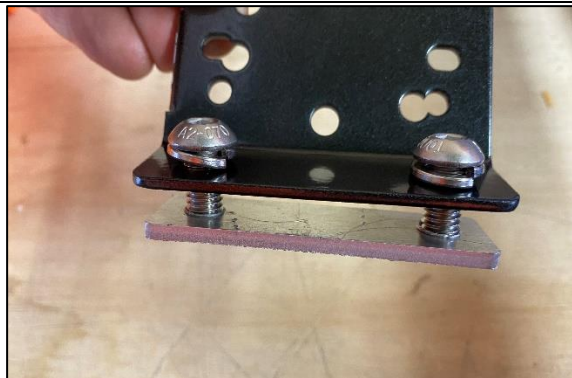

STEP 2.1 FIT THE NUT PLATE TO THE JBA BRACKET USING M8 BUTTON HEAD WITH SPRING WASHER AS SHOWN. ONLY SCREW IN TO NUT PLATE 1-2 TURNS.



STEP 2.2 SLIDE ONE END OF THE NUT PLATE INTO THE CENTRE OPENING OF THE REAR CHANNEL OF THE RACK



STEP 2.3 SLIDE THE BRACKET ALL THE WAY INTO THE CHANNEL AND TIGHTEN FULLY WHEN IN POSITION.

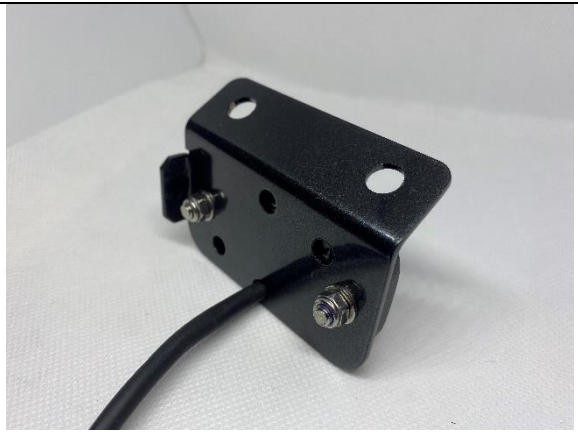

STEP 2.4 FIT ROK9 LIGHT TO JBA BRACKET USING M5 X 16 PAN HEAD AND WASHER WITH NYLOC NUT FROM BEHIND AS SHOWN.

3. INSTALL TO TRADESMAN WEDGETAIL SIDE MOUNT



STEP 3.1-

OPTION 1 LOCATING ONE HOLE USING CHANNEL NUT

IF USING A CHANNEL NUT LOCATION, REMOVE TRADESMAN M8 BOLT AND POSITION ROK 9 BRACKET USING M8 DOME HEAD AND SPRING WASHER. MARK THE OTHER HOLE AS SHOWN.



OPTION 2 NOT USING CHANNEL NUT

POSITION THE BRACKET IN DESIRED LOCATION AND MARK BOTH HOLES ON TRADESMAN RACK.



STEP 3.2- DRILL OUT MARKED HOLES TO 8-9MM. IT IS EASIE TO DO THIS WITH THE RACK OFF THE VEHICLE IF POSSIBLE.



STEP 3.3- FIT BRACKET TO RACK USING M8 BUTTON HEAD WITH SPRING WASHER ON UNDER SIDE AND M8 WASHER WITH NYLOC NUT FROM TOP SIDE (ON ALL HOLES NOT UTILISING CHENNEL NUT AS PER STEP 3.1, OPTION 1).

FIT ROK9 LED TO JBA BRACKET USING M5 X 16 PAN HEAD WITH WASHER AND NYLOC FROM BEHIND.